



VALVOLE SIRSI - TIPO "FLAV-P.C." A FLUSSO  
AVVIATO PRESSIONE CHIUDE

TYPE "FLAV-P.C." PRESSURE CLOSING  
SIRSI VALVES

VANNES SIRSI - TYPE "FLAV-P.F." - PRESSION  
FERME

**TN 2032**

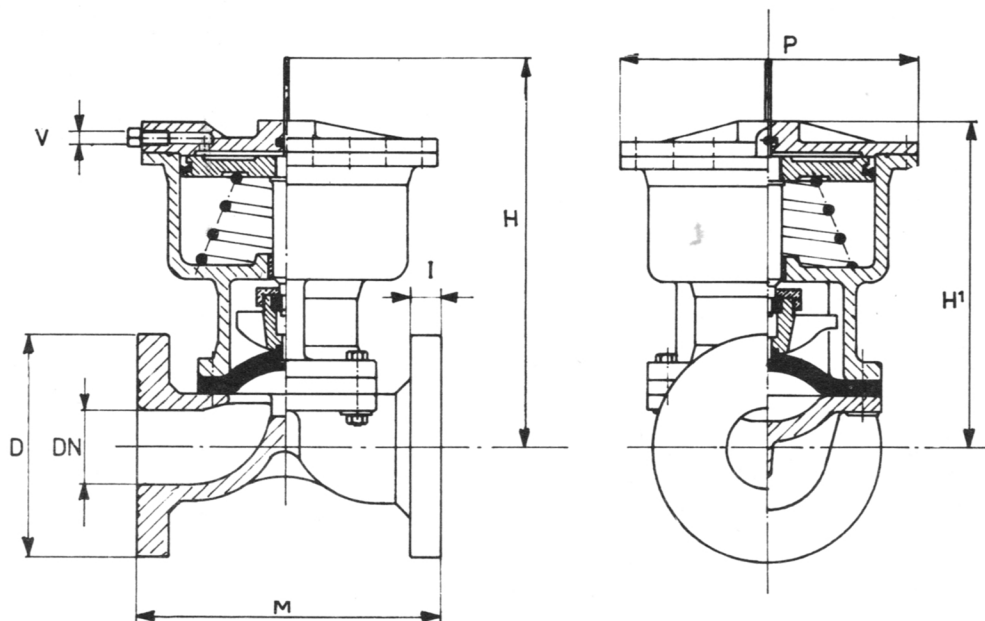

**CARATTERISTICHE E DIMENSIONI - SPECIFICATIONS AND DIMENSIONS - CARACTERISTIQUES ET DIMENSIONS**

DN	D	H	I	L <sub>1</sub>	M	P	V	Press. max. Bar	Pesi Weights - Poids Kg.	NOTE
15	95	265	14	180	108	150	1/4" G	10	3,800	
20	105	265	16	180	117	150	1/4" G	10	4,000	
25	115	290	16	205	127	150	1/4" G	8	6,700	
32	140	295	18	210	146	150	1/4" G	8	8,100	
40	150	410	18	275	164	200	1/4" G	7	12,500	
50	165	410	20	285	190	200	1/4" G	7	15,300	
65	185	430	20	295	216	200	1/4" G	7	19,600	
80	200	460	22	315	254	285	1/4" G	7	34,500	
100	220	470	22	335	305	285	1/4" G	6	43,000	
125	250	710	24	530	356	372	1/4" G	4	75,000	
150	285	750	24	570	406	372	1/4" G	4	82,000	
200	340	855	28	650	520	450	1/4" G	3	128,000	
250	395	1070	32	720	635	450	1/4" G	3	202,500	
300	445	1300	32	1100	749	450	1/4" G	3	237,500	

Valvola costantemente aperta in posizione di riposo. Chiusura mediante immissione di aria compressa nel cilindro pneumatico.

**Cilindro e pistone:** in lega di alluminio.

**Caratteristiche costruttive:** identiche a quelle del tipo "FLAV" normale (TN 2028).

**N.B.:** le valvole "FLAV-PC" vengono anche fornite con scartamenti DIN (cfr. TN 2028/A), con attacchi filettati (cfr. TN 2028/B) e con corpo a squadra (cfr. TN 2028/C).

Normally open valve. Delivery of compressed air to the pneumatic cylinder closes the valve.

**Cylinder and piston:** aluminum alloy.

**Construction features:** as per normal type "FLAV" (TN 2028).

**N.B.:** type "FLAV-PC" valves are also supplied with DIN length over flanges (see TN 2028/A) with screwed ends (see TN 2028/B) and with angle body (see TN 2028/C).

Vanne normalmente ouverte. Fermeture de la vanne par admission d'air comprimé dans le cylindre pneumatique.

**Cylindre et piston:** en alliage en aluminium.

**Caractéristiques constructives:** identiques à celles du type "FLAV" normal (TN 2028).

**N.B.:** les vannes "FLAV-PF" sont également fournies avec encombrements DIN (cfr. TN 2028/A) avec extrémités taraudées (cfr. TN 2028/B) et avec corps d'équerre (cfr. TN 2028/C).